

Mouth-watering display

Hot Deli 3



The Hot Deli curved merchandisers are available in 3, 4 and 5 GN-pan sizes. It can be built-in into existing counters or installed on a matching floor-mounted stand. The Hot Deli can also be combined with the Cold Deli to display both your hot and cold food products in one matching design.

The Hot Deli full serve humidified and self serve are based on simplicity. All basic features are united in these cabinets without quality and finishing being compromised. These counters contain the perfect holding conditions to keep your products fresh.

The Hot Deli is complete in functionality. It features independent upper radiant heat to control humidity over each GN-section. In order to ensure ideal holding conditions, humidification can be set at four different levels. The mild airflow enables you to hold and display the most versatile food products with different holding requirements.

Features Hot Deli 3 Curved

Top features

- Curved glass
- Available in full serve humidified and self serve model
- Plug and play
- Long holding time: based on constant temperature and mild airflow

Standard characteristics

- Product temperature maintained at 149-158°F
- Reflector-enhanced halogen lighting for attractive promotion
- Hot and cold, full serve humidified and self serve can be combined in one design
- Ergonomically designed for maximum operator convenience
- Available in curved and square glass
- Mirrored sliding doors at operator side
- Stainless steel interior and stainless steel exterior
- Full serve humidified: 4-step humidified operation with built-in low water alarm
- Independently controlled upper radiant heat per section
- 3x1/1 GN-pan plus 3x1/3 GN-pan per section
- Front glass lifts and closes easily on gas springs
- Self serve: simple three-button control
- Self serve: flat plate: 38 x 237/8"

Accessories

- Cutting board
- Temperature indicator customer side
- Second level display rack
- Matching stands

Optional

- Full serve humidified or self serve model
- Automatic water-filling system



Hot Deli 3 Curved full serve humidified



Hot Deli Square



Control panel Premium



Second level

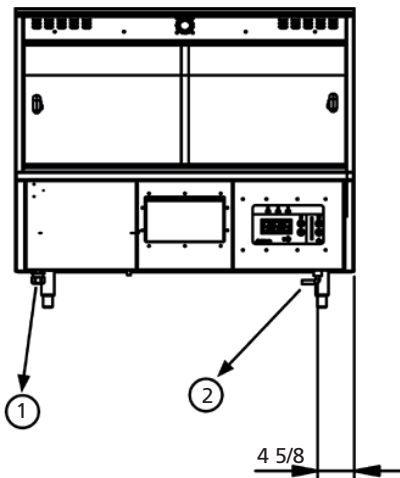
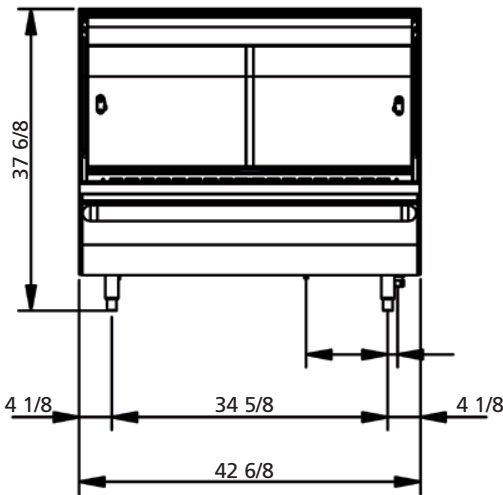
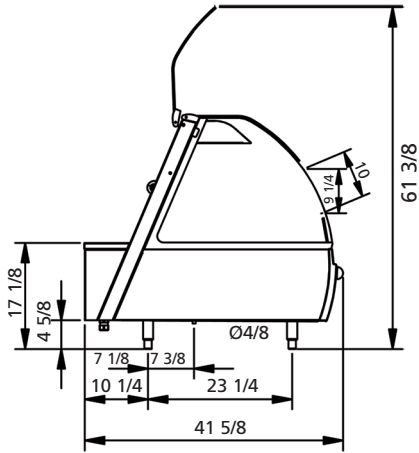
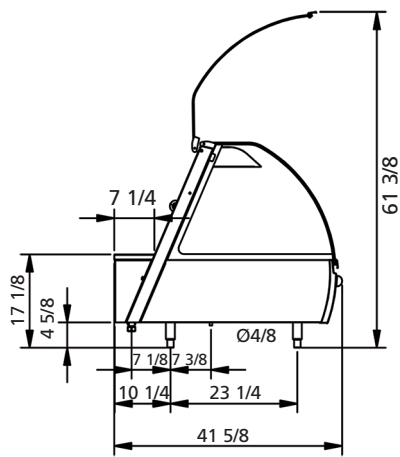

HD 3 full serve HD 3 self serve
humidified

Full serve operation	■	
Self serve operation		■
Available in curved glass or square glass	■	■
Mirrored sliding rear doors	■	■
Three-button control panel		■
Digital control panel	■	
4-step humidity	■	
Built-in low water alarm	■	
Radiant heat	■	■
Independently controlled radiant heat per GN section	■	
Front glass lifts on gas springs	■	
Panframe standard	■	optional
Flat plate standard	optional	■
Cutting board	optional	optional
Automatic water filling system	optional	
Second level display rack	optional	optional
Temperature indicator	optional	optional

HD 3 full serve HD 3 self serve
humidified

Width	42 6/8"	42 6/8"
Depth	41 5/8"	41 5/8"
Height	37 6/8"	37 6/8"
Height on stand	55 7/8"	55 7/8"
Net weight	346 lbs	300 lbs
Gross weight	408 lbs	353 lbs
Voltage	208 V	208 V
Phase	3~	3~
Frequency	50/60 Hz	50/60 Hz
Power	4.6 kW	3.7 kW
Plug	NEMA 15-20P	NEMA 15-20P

Hot Deli 3 Curved

- 1 Power cable 95"
- 2 Hose pillar (automatic water-filling only)

Specifications and technical data are subject to amendment without notice.

These are basic drawings. For more detailed technical information, please refer to the installation manual at www.frijado.com.



Fri-Jado Inc.
1401 Davey Road
Suite 100
Woodridge IL 60517
Toll free 877-374-5236
Fax 630-689-1424
e-mail us.info@frijado.com
usa.frijado.com

Mouth-watering display

Hot Deli 4



The Hot Deli square merchandiser is available in 3, 4 and 5 GN-pan sizes. It can be built-in into existing counters or installed on a matching floor-mounted stand. The Hot Deli can also be combined with the Cold Deli to display both your hot and cold food products in one matching design.

The Hot Deli full serve humidified and self serve are based on simplicity. All basic features are united in these cabinets without quality and finishing being compromised. These counters contain the perfect holding conditions to keep your products fresh.

The Hot Deli is complete in functionality. It features independent upper radiant heat to control humidity over each GN-section. In order to ensure ideal holding conditions, humidification can be set at four different levels. The mild airflow enables you to hold and display the most versatile food products with different holding requirements.

Features Hot Deli 4 Curved

Top features

- Curved glass
- Available in full serve humidified and self serve model
- Plug and play
- Long holding time: based on constant temperature and mild airflow

Standard characteristics

- Product temperature maintained at 149-158°F
- Reflector-enhanced halogen lighting for attractive promotion
- Hot and cold, full serve humidified and self serve can be combined in one design
- Ergonomically designed for maximum operator convenience
- Mirrored sliding doors at operator side
- Stainless steel interior and stainless steel exterior
- Full serve humidified: 4-step humidified operation with built-in low water alarm
- Independently controlled upper radiant heat per section
- 4x1/1 GN-pan plus 4x1/3 GN-pan per section
- Front glass lifts and closes easily on gas springs
- Self serve: simple three-button control
- Self serve: flat plate: 51 1/8 x 23 7/8"

Accessories

- Cutting board
- Temperature indicator on customer side
- Second level display rack
- Matching stands

Optional

- Full serve humidified or self serve model
- Automatic water-filling system



Hot Deli 4 Curved full serve humidified



Hot Deli Square



Control panel Premium



Second level

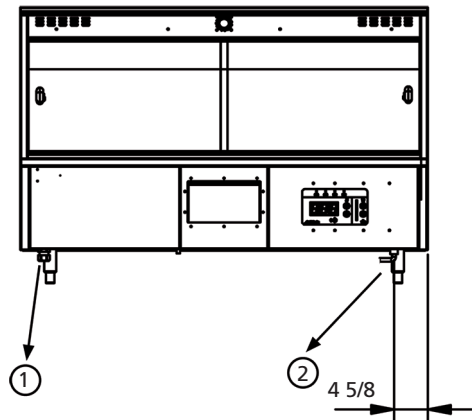
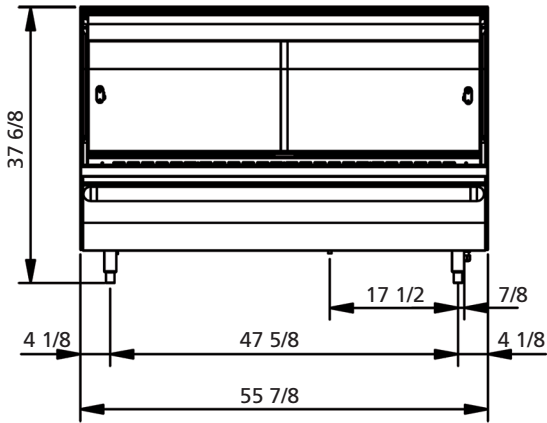
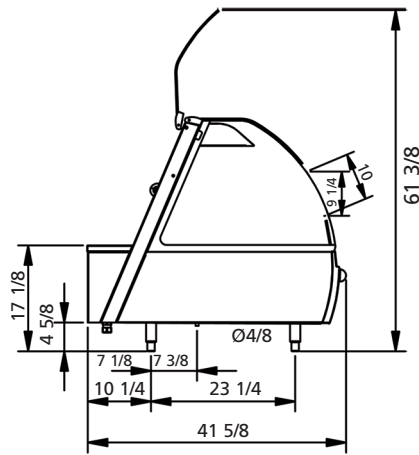
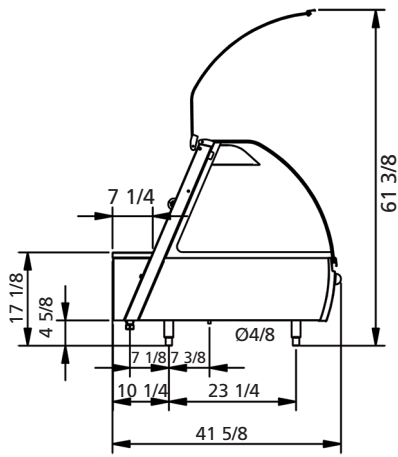

HD 4 full serve HD 4 self serve
humidified

Full serve operation	■	
Self serve operation		■
Available in curved glass or square glass	■	■
Mirrored sliding rear doors	■	■
Three-button control panel		■
Digital control panel	■	
4-step humidity	■	
Built-in low water alarm	■	
Radiant heat	■	■
Independently controlled radiant heat per GN section	■	
Front glass lifts on gas springs	■	
Panframe standard	■	optional
Flat plate standard	optional	■
Cutting board	optional	optional
Automatic water filling system	optional	
Second level display rack	optional	optional
Temperature indicator	optional	optional

HD 4 full serve HD 4 self serve
humidified

Width	55 7/8"	55 7/8"
Depth	41 5/8"	41 5/8"
Height	37 6/8"	37 6/8"
Height on stand	55 7/8"	55 7/8"
Net weight	463 lbs	414 lbs
Gross weight	545 lbs	487 lbs
Voltage	208 V	208 V
Phase	3~	3~
Frequency	50/60 Hz	50/60 Hz
Power	4.9 kW	4 kW
Plug	NEMA 15-20P	NEMA 15-20P

Hot Deli 4 Curved

- 1 Power cable 95"
- 2 Hose pillar (automatic water-filling only)

Specifications and technical data are subject to amendment without notice.

These are basic drawings. For more detailed technical information, please refer to the installation manual at www.frijado.com.



Fri-Jado Inc.
1401 Davey Road
Suite 100
Woodridge IL 60517
Toll free 877-374-5236
Fax 630-689-1424
e-mail us.info@frijado.com
usa.frijado.com

Mouth-watering display

Hot Deli 5



The Hot Deli curved merchandisers are available in 3, 4 and 5 GN-pan sizes. It can be built-in into existing counters or installed on a matching floor-mounted stand. The Hot Deli can also be combined with the Cold Deli to display both your hot and cold food products in one matching design.

The Hot Deli full serve humidified and self serve are based on simplicity. All basic features are united in these cabinets without quality and finishing being compromised. These counters contain the perfect holding conditions to keep your products fresh.

The Hot Deli is complete in functionality. It features independent upper radiant heat to control humidity over each GN-section. In order to ensure ideal holding conditions, humidification can be set at four different levels. The mild airflow enables you to hold and display the most versatile food products with different holding requirements.

Features Hot Deli 5 Curved

Top features

- Curved glass
- Available in full serve humidified and self serve model
- Plug and play
- Long holding time: based on constant temperature and mild airflow

Standard characteristics

- Product temperature maintained at 149-158°F
- Reflector-enhanced halogen lighting for attractive promotion
- Hot and cold, full serve humidified and self serve can be combined in one design
- Ergonomically designed for maximum operator convenience
- Mirrored sliding doors at operator side
- Stainless steel interior and stainless steel exterior
- Full serve humidified: 4-step humidified operation with built-in low water alarm
- Independently controlled upper radiant heat per section
- 5x1/1 GN-pan plus 5x1/3 GN-pan per section
- Front glass lifts and closes easily on gas springs
- Self serve: simple three-button control
- Self serve: flat plate: 64 1/8" x 23 7/8"

Accessories

- Cutting board
- Temperature indicator on customer side
- Second level display rack
- Matching stands

Optional

- Full serve humidified or self serve model
- Automatic water-filling system



Hot Deli 5 Curved full serve humidified



Hot Deli Square



Control panel Premium



Second level

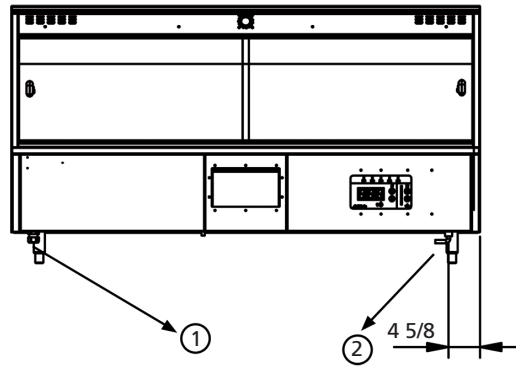
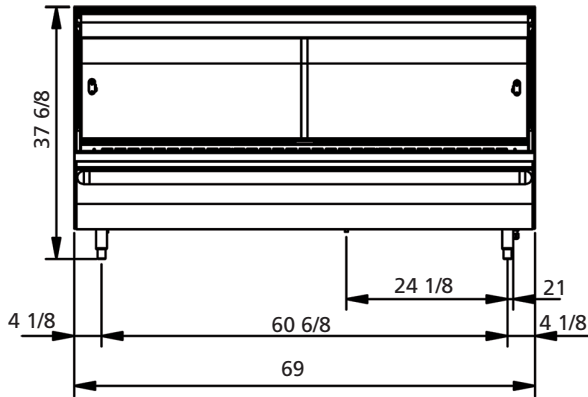
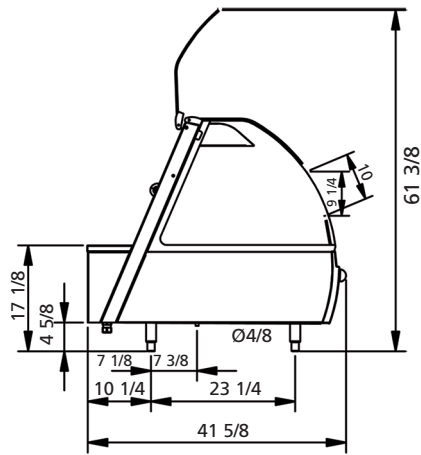
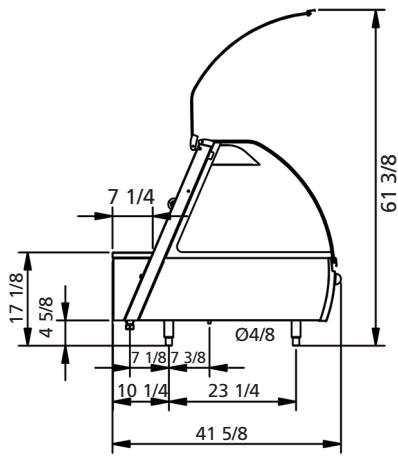

Hot Deli 5 Curved

- 1 Power cable 95"
- 2 Hose pillar (automatic water-filling only)

Specifications and technical data are subject to amendment without notice.

These are basic drawings. For more detailed technical information, please refer to the installation manual at www.frijado.com.



HD 5 full serve HD 5 self serve humidified

Full serve operation	■	
Self serve operation		■
Available in curved glass or square glass	■	■
Mirrored sliding rear doors	■	■
Three-button control panel		■
Digital control panel	■	
4-step humidity	■	
Built-in low water alarm	■	
Radiant heat	■	■
Independently controlled radiant heat per GN section	■	
Front glass lifts on gas springs	■	
Panframe standard	■	optional
Flat plate standard	optional	■
Cutting board	optional	optional
Automatic water filling system	optional	
Second level display rack	optional	optional
Temperature indicator	optional	optional

HD 5 full serve HD 5 self serve humidified

Width	69"	69"
Depth	41 5/8"	41 5/8"
Height	37 6/8"	37 6/8"
Height on stand	55 7/8"	55 7/8"
Net weight	529 lbs	478 lbs
Gross weight	622 lbs	562 lbs
Voltage	208 V	208 V
Phase	3~	3~
Frequency	50/60 Hz	50/60 Hz
Power	5.1 kW	4.2 kW
Plug	NEMA 15-20P	NEMA 15-20P

Fri-Jado Inc.

1401 Davey Road

Suite 100

Woodridge IL 60517

Toll free 877-374-5236

Fax 630-689-1424

e-mail us.info@frijado.com

usa.frijado.com